

Mechanical Cam Switches
BNS 816-X849-B06-00-12-610-11
Order Code: BNS03N9



Remarks

Mutual interference of the switching function BES 517-100-S42
BES 517-100-S43
BES 517-100-S44 excluded due to different oscillator frequencies.
Connection / pin assignments determined by customer. Does not correspond to a known technical standard.

Connector Drawings

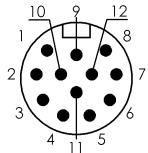

View of connector side

Wiring Diagrams

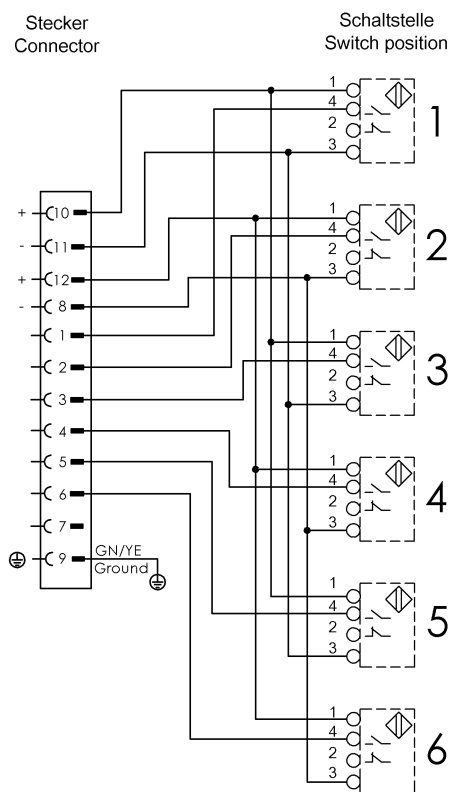

PE mit Gehäuse verbunden
Ground connected to housing